

Depth Gage

A standard measuring tool of industry

Extension Bases Optional accessory for Depth Gage

- Attaches to the base (reference face) plate of a depth gage to extend its span.
- Refer to the illustrations at left for attachment details.
- Extension base is three times the length of the base for models of less than 300mm range.
- These extension bases cannot be attached to 0-600mm, 0-1000mm, 0-24" and 0-40" range models.



900372

SPECIFICATIONS

Metric			Inch		
Order No.	Size L	n	Order No.	Size L	n
900370	180mm	2	900367	7"	2
900371	260mm	5	900368	10"	5
900372	320mm	4	900369	12"	4

DIMENSIONS

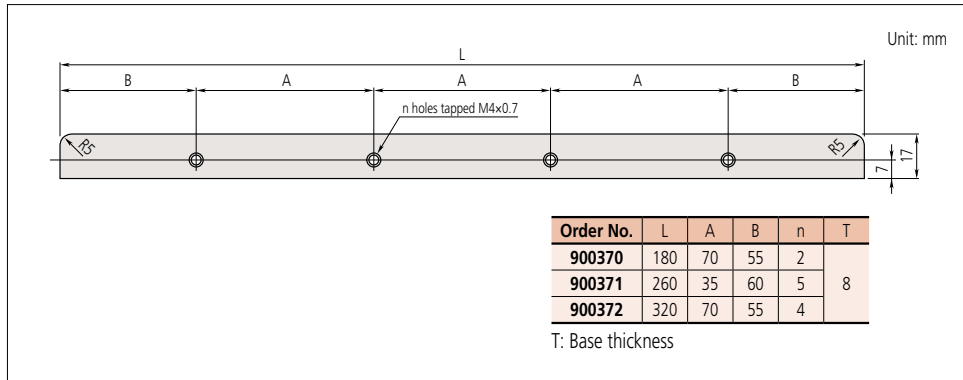

Example of attaching the extension base

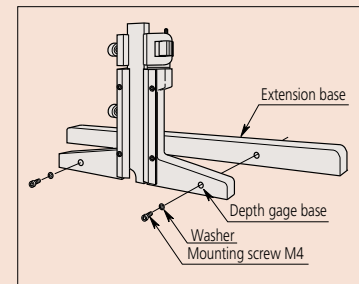
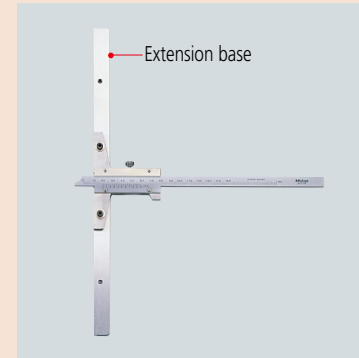

Depth Gage Attachment Optional Accessory for Calipers

- Attaching this depth gage attachment to the depth measurement face of the caliper makes depth measurement accurate and secure.

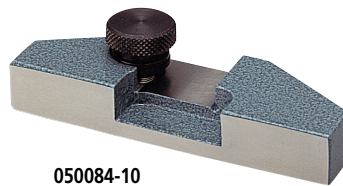

050084-10

SPECIFICATIONS

Order No.	Size	Applicable measuring range of caliper
050083-10	75mm	100mm, 150mm, 200mm, 4", 6" and 8"
050084-10	100mm	100mm, 150mm, 200mm, 4", 6" and 8"
050085-10	125mm	300mm and 12"

DIMENSIONS

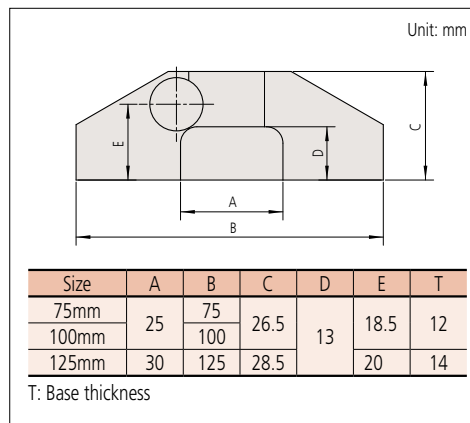

Example of attaching the extension base

