

Depth Gage

A standard measuring tool of industry

Vernier Depth Gage SERIES 527

- Standard gage for depth measurement.
- Optional longer extension bases are available. (Except for models with measuring ranges of 600 and 1000mm)

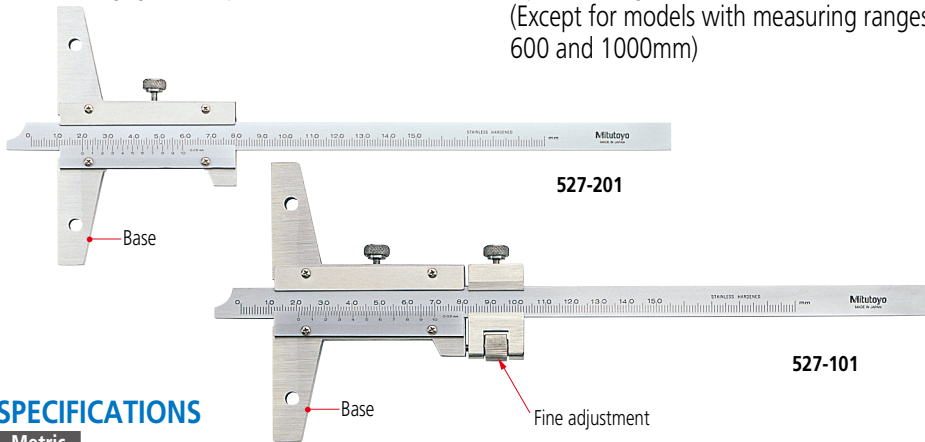

SPECIFICATIONS

Metric

Order No.	Range	Vernier reading	Accuracy	Base (W x T)	Remarks
527-201	0 - 150mm	0.05mm	±0.05mm	100 x 6.5mm	—
527-202	0 - 200mm		±0.08mm		—
527-203	0 - 300mm		±0.10mm		—
527-204	0 - 600mm	0.05mm	±0.10mm	250 x 10mm	—
527-205	0 - 1000mm		±0.15mm		—

Metric

Order No.	Range	Vernier reading	Accuracy	Base (W x T)	Remarks
527-101	0 - 150mm	0.02mm	±0.03mm	100 x 6.5mm	with fine adjustment
527-102	0 - 200mm				

Inch

Order No.	Range	Vernier reading	Accuracy	Base (W x T)	Remarks
527-111	0 - 6"	.001"	±.001"	3.93" x .25"	with fine adjustment
527-112	0 - 8"		±.0015"		
527-113	0 - 12"		±.002"	9.8" x .39"	
527-114	0 - 24"		±.002"		
527-115	0 - 40"		±.003"		

DIMENSIONS

