

Test stand

MX-500N / MV-500NII series

Motorized Test Stand



(Photo is MX-500N-E. Force gauge and speed/length meter are sold separately.)

[Applications]

- Various material testing up to 500N
(measuring of tensile strength, compressive strength, shearing strength and etc).
- Analysis of mechanical parts for break point and free fit.

[Features]

- Stable measuring by feed screw features with small step of the travel length.
- Suitable for Imada brand digital and mechanical force gauges.
- Overload protection and force control connecting with digital force gauge (Only for MX series)
- Optional scale unit implements scaling its travel length.

[MX-500N/MV-500NII series models]

Stroke	Scale unit	Speed/Length meter	MX-500N Series	MV-500NII Series	Capacity
Normal			MX-500N	MV-500NII	500N
	Yes		MX-500N-S	MV-500NII-S	500N
		Yes	MX-500N-E	MV-500NII-E	500N
Long stroke			MX-500N-L	MV-500NII-L	200N
	Yes		MX-500N-S-L	MV-500NII-S-L	200N
		Yes	MX-500N-E-L	MV-500NII-E-L	200N

Model number will be followed with below suffixes when you specify speed range.

Suffix	Speed range	Capacity
-WF	40 – 1200 mm/min	200N
-F	20 – 600 mm/min	500N 200N (Long stroke)
-O	2 – 60 mm/min	500N 200N (Long stroke)

[MX-500N/MV-500NII series specifications]

Model	MX-500N	MV-500N
Capacity	500N (Normal) 250N (Long stroke)	
Stroke	Approx. 285mm (Normal) Approx. 485mm (Long stroke)	
Feeding method	Feed screw with 3mm lead	
Travel speed	10 to 300 mm/min non-step (No specified)	
Table	150 x 100 mm, (Aluminum / Stainless plate cover)	
Force gauge	Imada mechanical / digital force gauge (Except high capacity models)	
Single/Continuous cycle	Yes	Press and keep to continue moving
Overload protection Force control	Yes *0	Press and keep button for 2 seconds so that this machine keeps moving
Dimensions	See dimensions	
Wight	Approx. 18kg	
Accessories	Grip mount GF-1 (M6 thread)	

*0 Optional cable CB-501 is necessary for connection with force gauge. Some model of force gauge is not compatible with this function.

[MX-500N/MV-500NII series specifications]

Factory built only. The customer can not build them after purchasing.

Scale unit (option *1)	Resolution: 0.01mm Zero / Origin
Length/speed meter (option *2)	EN-00 Speed resolution 1mm/min Length resolution 0.01mm Zero
Speed range	See models

*1 Factory built only for MX/MV-500N-S

*2 Factory built only for MX/MV-500N-E. See a brochure for EN-00

[Dimensions]

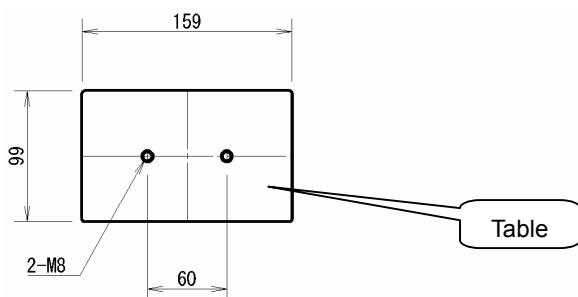

寸法 H(mm)

型式	H	T
MX/MV-500N(-S)	573	285
MX/MV-500N(-S)-L	773	485
MX/MV-500N-E	633	285
MX-MV-500N-E-L	833	485

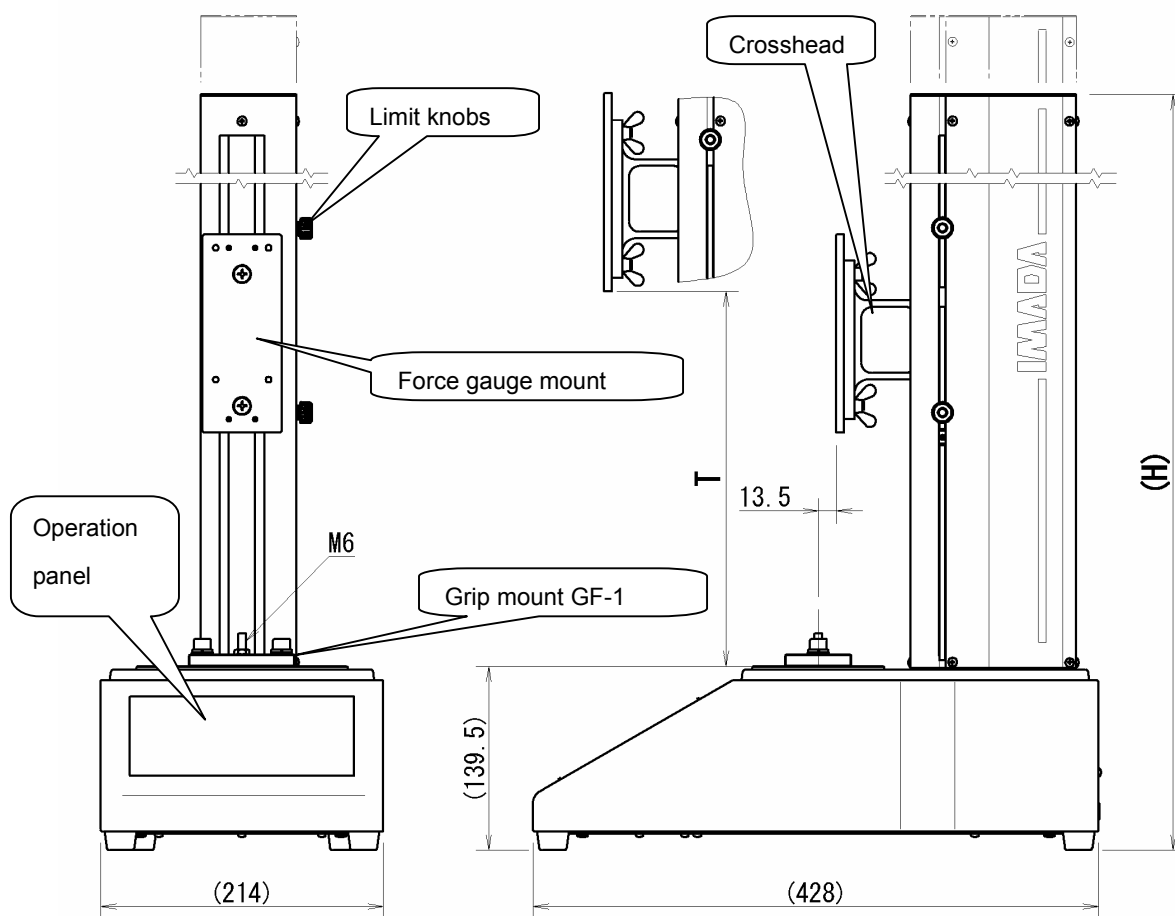

[Note]

- Force gauge is not included with this test stand.
- Various optional attachments are available.
- "Overload protection" does NOT completely avoid every failure of the gauge.
- Please do not apply the load exceeding force of capacity.
- Please avoid rapid temperature change, high humidity, the water, the dust, and the strong shock.
- It may change without a preliminary announcement for improvement etc.