

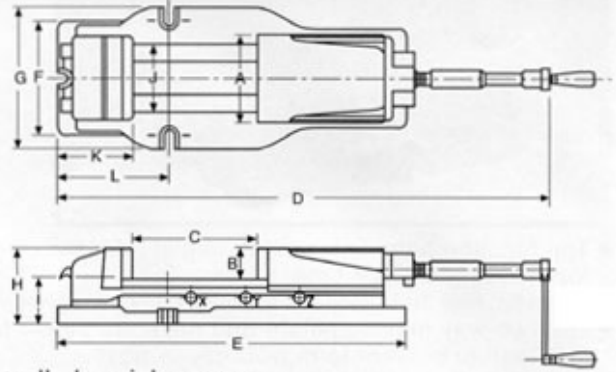

MATCHLING TOOLING

35050

HYDRAULIC MACHINE VISE

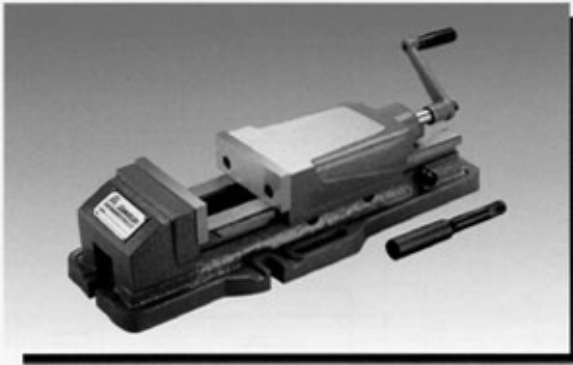

- Hydraulic inside, pressure designed , just light knock handle by wink power
It auto change to pressure enter
- The body and fixed clamping are unity , manufactured by FC30 iron cast,
rigidity is strong not easy to change shape
- Slipping side of vise heat treatment up HRC 45° up, and grind precision

Unit:mm

Order No.	Model	A	B	C	D	E	F	G	H	I	J	K	L	X	Y	Z	Pressure	N.W.
35050-04	HV400	105	36	0-170	525	440	135	170	95	58	80	95	147	0-57	55-114	112-170	2500kg	21kg
35050-05	HV500	130	48	0-220	670	550	175	207	120	70.5	97	107	195	0-73	72-146	145-220	3000kg	38kg
35050-06	HV600	150	53	0-300	800	620	182	225	135	82.5	116	117	210	0-100	98-200	198-300	4500kg	53kg
35050-08	HV800	200	62	0-300	900	680	260	280	162	100	160	150	260	0-100	99-200	198-300	8000kg	95kg

35051

PRECISION HYDRAULIC & ANGLE LOCK VISE

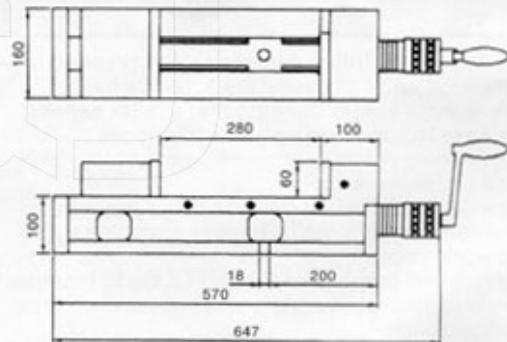
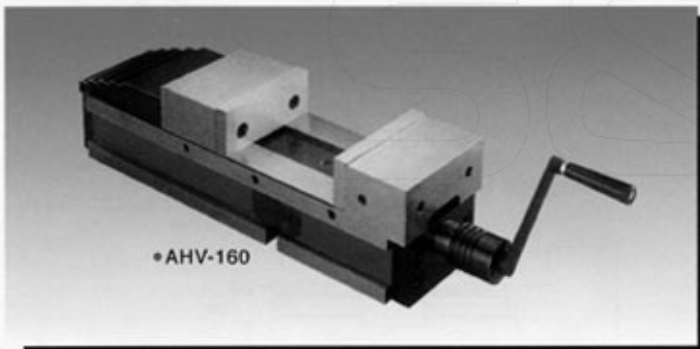

- Movable jaw located at outer end and "align surface" for workpiece is in front of operator.
It is convenient for loading or unloading workpiece on such design of hydraulic vise.
- The overall length of this vise is shorter than other similar vises, but keep the same jaw opening.
Save space on work table.

FEATURES:

- 1.Angle-lock type Hydraulic vise model:AHV-160 is mostly suitable for heavy duty cutting on Vertical Machining center.
- 2.Semi-spherical segment eliminates jaw lifting and workpiece tilting.
- 3.Rigid material ductile iron FCD60 with 60kgs/mm ensures high tensile strength, low weariness and not deformation.
- 4.Vise bed flame hardened to HRC45 up is capable to obtain low weariness and last the high accuracy for long.
- 5.Four (4) different jaws set up can be obtained.
- 6.Chip covers is applied on this vise to prevent from chips falling to Leadscrew and inside of vise.

SPECIFICATION:

- Jaw width.....160mm
- Jaw opening.....280mm
- Depth of Jaws.....60mm
- Overall length.....647mm
- Net weight (approx).....60kg