

Calipers

An industry standard in measuring tools

SuperCaliper SERIES 500 — No battery or origin reset needed for IP67 digital caliper

- Top-of-the-line digital caliper. Solar type caliper with no battery and IP67 protection assures waterproof reliability.

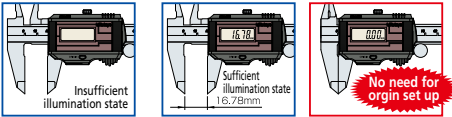

- With no annoying origin restoration necessary, a measurement can be started any time and there is no restriction on operating speed.
- The impact resistance of the display unit has been increased for improved usability in workshop conditions.

- Waterproof function makes this SuperCaliper suitable for use in an environment containing large amounts of cutting fluid or coolant. Operability is equivalent to the mechanical type caliper.
- This SuperCaliper uses components that do not contain harmful substances and is compatible with RoHS Directives.
- Slider operation is smooth and comfortable.

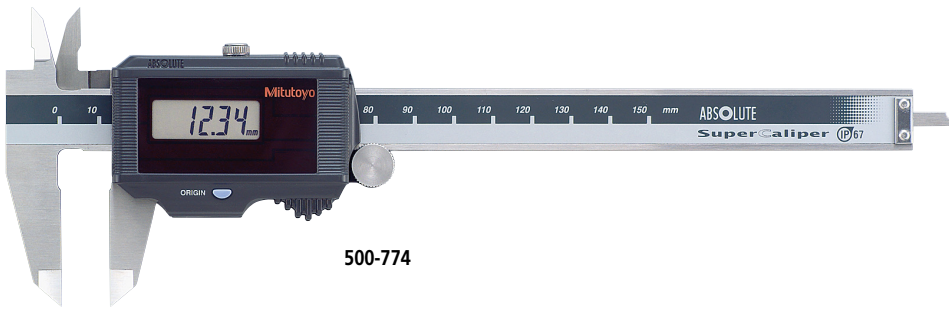
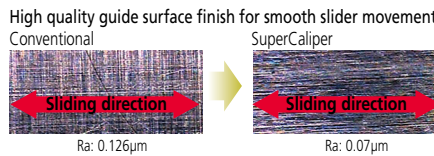

500-774

SPECIFICATIONS

Metric				Inch/metric			
Order No.	Range	Remarks	Mass	Order No.	Range	Remarks	Mass
500-776	0 - 150mm	with data output	180g	500-786	0 - 6"	with data output	180g
500-777	0 - 200mm		210g	500-787	0 - 8"		210g
500-774	0 - 150mm	w/o data output	180g	500-784	0 - 6"	w/o data output	180g
500-775	0 - 200mm		210g	500-785	0 - 8"		210g

DIMENSIONS

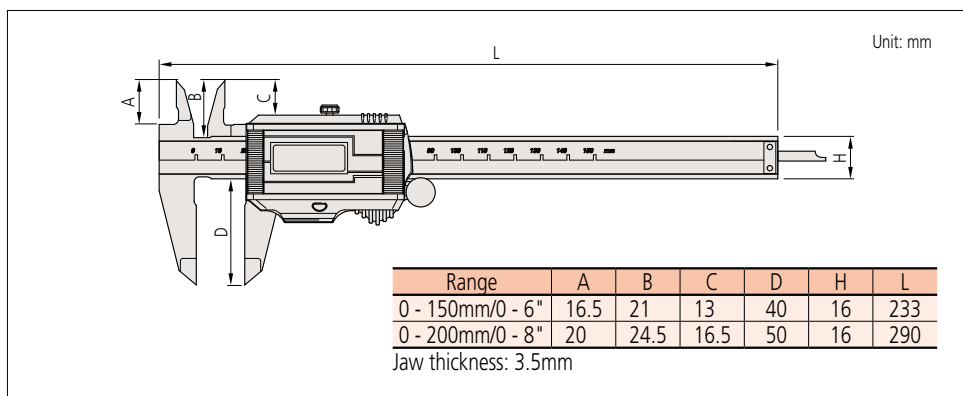

ABSOLUTE™ (Refer to page X for details.)

IP67 (Refer to page X for details.)



(Refer to page X for details.)



An inspection certificate is supplied as standard. Refer to page X for details.

IP67 protection level

- Level 6:** Dust-proof. No ingress of dust allowed.
- Level 7:** Protected against water penetration. Ingress of water in quantities causing harmful effects shall not be possible when the enclosure is temporarily immersed to a depth of 1 meter in water under standardized conditions of pressure and time (30 min.).

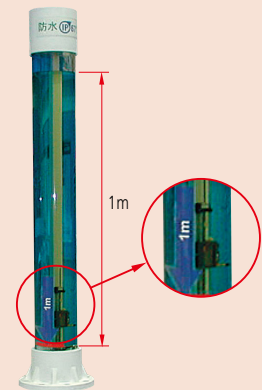

Demonstration device

Technical Data

- Resolution: 0.01mm or .0005"/0.01mm
- Accuracy: ±0.02mm (excluding quantizing error)
- Repeatability: 0.01mm
- Quantizing error: ±1 count
- Dust/Water protection level: IP67*
- Power supply: Solar cell**
- Display: LCD
- Scale type: ABSOLUTE electromagnetic induction linear encoder
- Max. response speed: Unlimited
- * This model is not waterproof type. Therefore, rustproofing shall be applied after use.
- ** Can be used continuously above 60lux ambient illumination.

