

# Micrometer

The origin of Mitutoyo's trustworthy brand of small tool instruments

## High-Accuracy Digimatic Micrometer SERIES 293

- Enabling 0.1µm resolution measurement, this micrometer is ideal for customers who need to make highly accurate measurements with a hand-held tool.
- The High-Accuracy Digimatic Micrometer utilizes Mitutoyo's innovative 0.1µm resolution ABS (absolute) rotary sensor\*1 and high-accuracy screw machining technology to reduce the instrumental error to ±0.5µm, delivering higher accuracy without sacrificing operability.  
\*1. Patent pending in Japan, the United States of America, the European Union, and China.
- A highly rigid frame and high-performance constant-force mechanism\*2 enable more stable measurement, while the clicks emitted while the workpiece is being measured assure the operator that measurement is proceeding normally.  
\*2. Patent pending in Japan, the United States of America, the European Union, and China.
- Body heat transferred to the instrument is reduced by a (removable) heat shield, minimizing the error caused by thermal expansion of the frame when performing handheld measurements.
- The ABS (absolute) rotary sensor also eliminates the need to perform origin setting each time the power is turned on, letting you start measuring straight away. With no possibility of overspeed errors, the High-Accuracy Digimatic Micrometer also delivers a higher level of reliability.
- The High-Accuracy Digimatic Micrometer has a range of features to enable flexible measurement, including switchable resolution (0.0001mm/0.0005mm), function lock and preset.
- Carbide-tipped measuring faces

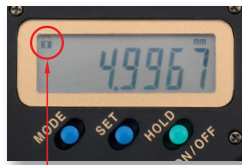

Function lock



- High-Accuracy Digimatic Micrometer received GOOD DESIGN AWARD 2011.



An inspection certificate is supplied as standard. Refer to page X for details.

**ABSOLUTE™** Absolute Encoder

### Technical Data

Measuring force: 7 to 9N  
Power supply: Lithium battery (CR2032) x 1  
Battery life: Approx. two years when used under normal conditions

### Functions

**Preset** (ABS measurement system):  
The measurement origin can be preset to any value within the display range for convenience in measuring.

**Zero-setting** (INC measurement system):  
The display can be zeroed at any position of the spindle, making comparison measurement easier. Returning to the absolute-measurement mode is easily accomplished.

**Hold:**  
The displayed value is held while the spindle is withdrawn and the micrometer moved so that the display can be read at the operator's convenience. After cancelling the hold, the instrument returns to the previous measuring mode (absolute or incremental).

**Resolution switching:**  
The resolution of the display can be switched. If 0.1µm measurement is not required, the resolution can be switched to 0.5µm.

**Function lock:**  
Functions such as preset or zero-set can be locked to avoid inadvertently changing the origin position.

**On/off:**  
The power can be turned off after measurement is complete. Even after the power is turned off, the origin or last zero-set position remains in the memory.

**Auto power off:**  
Even if the power is left on, the power turns off automatically if the micrometer is not used within a 20-minute period.

**Measurement data output:**  
Measurement data can be output, allowing easy incorporation of this instrument into a statistical process control or measurement system.

**Error alarm:**  
In the unlikely event of a display overflow or calculation error, an error message is displayed and measurement stops. Measurement cannot continue until the error is corrected.

Also, if the battery voltage drops below a certain point, the battery indicator will turn on before measurement becomes impossible, warning the user that the battery needs to be replaced.

## Standard accessories

Heat shield (No.04AAB969A: 293-100  
No.04AAB969B: 293-130) x 1  
Lithium battery CR2032 (1 pc),  
for initial operational checks (standard accessory)  
Spanner (No.200877) x 1  
Screwdriver (No.04AAB985) x 1  
Cleaning paper for measuring faces  
Inspection certificate



With heat shield\*  
attached

Heat shield



## Optional accessories

Connecting cables with output switch

1m: No. 05CZA662

2m: No. 05CZA663

USB Input Tool Direct

USB-ITN-B (2m): No. 06ADV380B

Connecting cables for U-WAVE-T (160mm)

No. 02AZD790B

For foot switch: No. 02AZE140B

Refer to page B-68 for details.

Cleaning paper for measuring faces (1000sheet): No.04AZB581



## DIMENSIONS

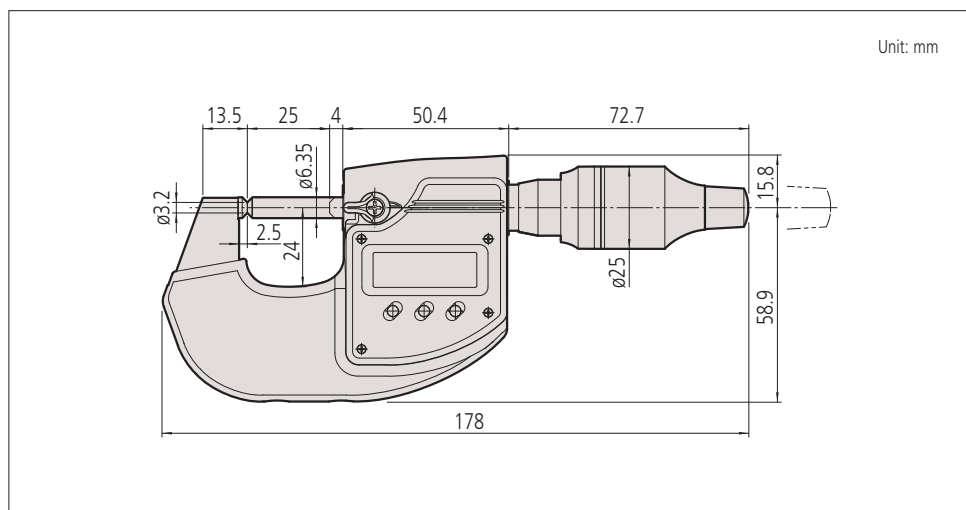

## SPECIFICATIONS

### Metric

Order No.	Range	Resolution	Accuracy*	Anvil/spindle faces	Mass
293-100	0 - 25mm	0.0001mm/0.0005mm (switchable)	$\pm 0.5\mu\text{m}$	$\phi 3.2\text{mm}$	400g

\* Excluding quantizing error

### Inch/Metric

Order No.	Range	Resolution	Accuracy*	Anvil/spindle faces	Mass
293-130	0 - 1"	.000005"/.00002" 0.0001mm/0.0005mm (switchable)	$\pm .00002$ "	$\phi 3.2\text{mm}$	400g

\* Excluding quantizing error

